

LINEMAN BODY BELT

Updated Product

US Tools Lineman's Body Belts

- Available in full-floating, semi-floating, or fixed styles.
- They meet or exceed all OSHA regulations, which apply to positioning device systems, for power utilities (OSHA 1926.959) and telecommunications (OSHA 1910.268).
- They also meet or exceed standards ASTM F887 and CSA Z259.1.
- Each belt has a permanent tag, which identifies model number, serial number, size, and date of manufacture.
- The belts are made of six piles vulcanized coated neoprene nylon.



UST-LB042

STANDARD PARAMETER

D- Ring attached to the inner belt	2 Nos with 15 kN Tensile Strength
Effective Opening of the snap hook	22 mm
Belt Length (D-D)	20 Inch
Breaking Strength of snap hook	20 kN
Waist Strap Width	1-3/4 Inch (44 mm), with punched hole of 1 inch apart.
Buckle Type	Double-tongue Buckle/Quick-release buckle.
Load Capacity	133 Kg
Compliance	OSHA & ASTM

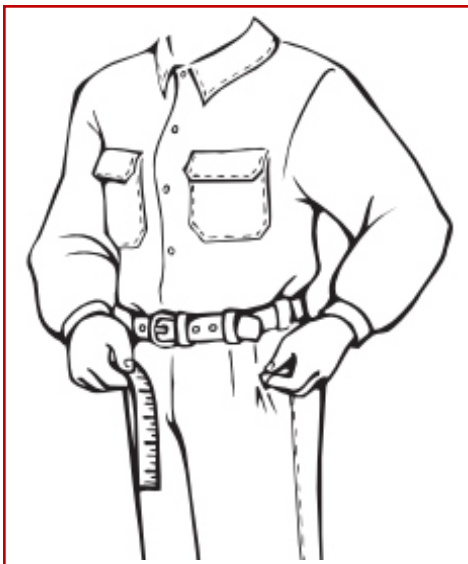

Size your body belt using a tape measure to obtain the correct D-to-D (D-ring to D-ring) size, measure around the back from hipbone to hipbone and then add 2" (51 mm)



Note: For Quality Reason, we have the right to change the color or design of the tools without any prior notice.



FEATURES

D-to-D Distance	Minimum Length	Center Hole Distance	Maximum Length
18D (46 cm)	32" (81 cm)	36" (91 cm)	40" (102 cm)
19D (48 cm)	33" (84 cm)	37" (94 cm)	41" (104 cm)
20D (51 cm)	34" (86 cm)	38" (97 cm)	42" (107 cm)
21D (53 cm)	36" (91 cm)	40" (102 cm)	44" (112 cm)
22D (56 cm)	37" (94 cm)	41" (104 cm)	45" (114 cm)
23D (58 cm)	38" (97 cm)	42" (107 cm)	46" (117 cm)
24D (61 cm)	40" (102 cm)	44" (112 cm)	48" (122 cm)
25D (64 cm)	41" (104 cm)	45" (114 cm)	49" (124 cm)
26D (66 cm)	42" (107 cm)	46" (117 cm)	50" (127 cm)
27D (69 cm)	44" (112 cm)	48" (122 cm)	52" (132 cm)
28D (71 cm)	45" (114 cm)	49" (124 cm)	53" (135 cm)
29D (74 cm)	46" (117 cm)	50" (127 cm)	54" (137 cm)
30D (76 cm)	47" (119 cm)	51" (130 cm)	55" (140 cm)



- Meets OSHA Regulations OSHA 1926.959 and ASTM F887
- Durable and reliable, our belts are crafted with high-quality nylon material, ensuring.
- Long-lasting 38 mm wide double-riveted 4 Nos. leather tool loops.
- Non-shock-absorbing rope Lanyard designed for positioning and restraint applications.
- Chromed Plated manual lock Buckle made of Zinced Carbon Steel
- 4-1/2 Inch Tanned-leather belt cushion with two laced and stitched pocket tabs

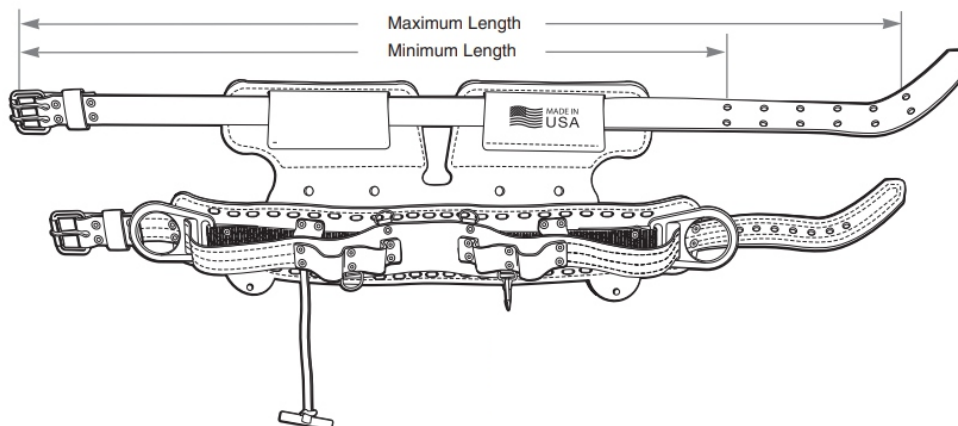
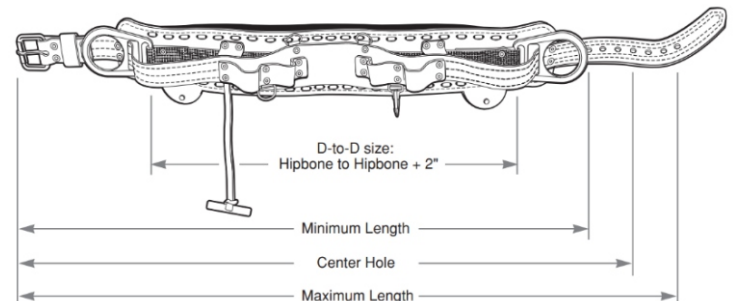

Note: For Quality Reason, we have the right to change the color or design of the tools without any prior notice.

